

OPERATION MANUAL

MODEL 135310

UNDER-DOOR REMOTE VIEWING KIT

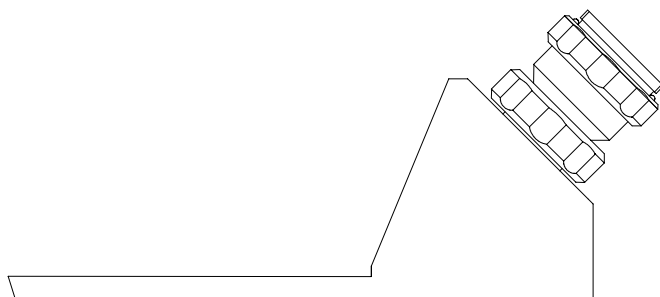

ITI | INSTRUMENT
TECHNOLOGY, INC.

POB 381, Westfield, MA 01086
33 Airport Road, Westfield, MA 01085

Tel: (413) 562-3606 Fax: (413) 568-9809 Email: iti@scopes.com

www.scopes.com

INTRODUCTION

Thank you for selecting Instrument Technology, Inc. (ITI) to fulfill your remote viewing needs.

Since 1967, ITI has been the Leader in Remote Viewing Instruments. The only company of its type doing all its manufacturing in the United States, ITI consistently provides cutting edge technology to customers world-wide.

ITI specializes in the design, development and manufacture of Remote Viewing Instruments (RVI) and systems including Borescopes, Fiberscopes and Videoscopes.

ITI offers over 2,000 standard products as well as products custom designed for unique applications. No matter which ITI product is used, our customers find they are able to observe hostile and difficult to reach environments never dreamed possible before. Though ITI products can solve many remote viewing problems, it is always best to select the proper instrument for any given application. Only then can success be assured.

Your satisfaction is guaranteed with all products purchased from Instrument Technology, Inc. Feel free to contact ITI or your local ITI Representative with any questions.

WARRANTY

Instrument Technology, Inc. warrants that the equipment is fit for the purposes described herein for a period of one year after the date of shipment when used in accordance with the directions for use, and agrees to repair or replace any such defective component part at no cost to the customer.

There are no other express or implied warranties. ITI's sole obligation and purchaser's exclusive remedy for breach of any warranty shall be limited to repair or replacement of the product at the option of ITI. This warranty does not cover, and ITI will not be liable for any resulting direct, proximate, incidental or consequential damages. This warranty does not apply if the product has been subject to misuse, negligence, accident or improper application, nor shall ITI be responsible for work done or repairs made by others.

PRODUCT SPECIFICATIONS

ITI Model 135310 Under-Door Remote Viewing Kit includes:

- (1) ITI Model 135310 Under Door Remote Viewing Instrument
- (1) ITI Model 135316 3 Way RA Viewing Adapter
- (1) Protective Carrying Case

Scope Specifications:

Thickness	0.19"	Field of View	55°
Working Length	3.5" or 7"	Line of Sight	15°

Optional Accessories:

- ITI Model 135311 Under Door Illuminator
- ITI Model 135312 Visual Eyepiece
- ITI Model 135315 Right Angle Viewing Adapter
- ITI Model 135313 Infrared Emitter Kit
- ITI Model 135314 Telescopic Arm
- ITI Model 135630 Night Vision Pocket Scope (NVPS)
- ITI Part Number 709-003K Nav2 & NAV3 Adapter Kit
- ITI Model 126070/41mm Visual Adapter
- ITI Model 125060A AC/DC 24W Light Source Kit
- Uni-Bar

OPERATING INSTRUCTIONS

OVERVIEW OF APPLICATIONS

ITI Model 135310 Under Door Remote Viewing Kit employs a unique probe intended for covert surveillance. The scope's 3.5" or 7.0" long blade is structured to allow surveillance into an adjacent room by utilizing the ¼" space available under most doorways.

The Right Angle Viewing Adapter allows the user to view behind doors to search for obstacles and/or barricades. Optional accessories, Infrared Emitter Kit , Night Vision Scope and video cameras can be used in low or no light situations.

This kit is intended to provide maximum resolution, portability and quick setup, and also features a dedicated "C" mount for video camera attachment.

INSTALLATION & MOUNTING

CAUTION

BORESCOPIES ARE DELICATE GLASS INSTRUMENTS, AND SHOULD BE TREATED ACCORDINGLY. PROPER HANDLING AND CLEANING TECHNIQUES WILL GREATLY INCREASE THE LIFE OF THIS INSTRUMENT. ONLY TRAINED OPERATORS SHOULD HANDLE THIS EQUIPMENT. **DO NOT BEND OR APPLY UNNECESSARY STRESS.**

UNDER-DOOR RVI INSERTION

The working length blade of this instrument is made from a hardened tool steel. Although it is designed to withstand normal field use for its intended application, the probe should never be forced.

The ¼" space available under most doorways allows sufficient clearance to utilize this instrument. With the scope fully assembled, for visual or video use, the blade should be carefully inserted under a doorway. Never use the RVI to pry door. If there is insufficient space to insert blade of scope, use a Uni-Bar to gently lift door, then insert blade. The Uni-Bar is an available item for purchase from ITI.

For initial insertion, the operator should view through the scope, using either eyepiece or monitor, to insure that a clear insertion path is available. If any obstructions are noticed, try another location.

It is also recommended that the initial insertion be performed without the Right Angle Adapter. This will allow for a better view to assess the condition within the room.

After the room has been fully viewed, the Right Angle Adapter can be used to observe the inside surface of the door. This is especially useful to detect for locks, braces or barricades.

For low, or no, light situations, optional accessories are available. Night Vision Scopes or low light video cameras greatly enhance low light scenes. The Infrared Emitter Kit also enhances the performance of Night Vision Scope for extremely dark rooms.

CAMERA CONNECTION

A standard "C" mount is supplied on the rear of the RVI. For use with 1/3" CCD cameras, use the "C" Mount Extender supplied with the camera. Screw camera onto the "C" mount or "C" Mount Extender until it bottoms out.

ITI recommends a 1/3" format CCD for use with this RVI. A 1/2" format CCD can also be used, although the monitor image will be quite small. ITI suggests the 1/2" format low light CCD camera with NVPS.

To obtain an upright image on the monitor, hold RVI stationary and rotate rear knob and camera together

VISUAL EYEPIECE

The Visual Eyepiece screws onto the "C" mount. The "C" Mount Extender should not be used when the Eyepiece is in place - you will not be able to obtain proper focus.

FOCUSING

Start with the RVI out of focus. Rotate Focus Ring so that focus is achieved and continue past clear focus. Rotate Focus Ring in opposite direction to re-establish clear focus.

RIGHT ANGLE ADAPTER

Slide Right Angle Adapter onto the blade, with mirror facing up, until it clicks in place. Note that the image reverts, left/right, when using this adapter. Use caution when removing Right Angle Adapter from blade. Grasp Right Angle Adapter by its sides and gently pull away from RVI.

CAUTION

THE MIRROR SURFACE ON THE RIGHT ANGLE ADAPTER SHOULD **NEVER BE TOUCHED**. TOUCHING THE MIRROR WILL CAUSE SCRATCHES OR A DIRT BUILD-UP THAT WILL DETERIORATE THE IMAGE QUALITY. SEE CLEANING INSTRUCTIONS.

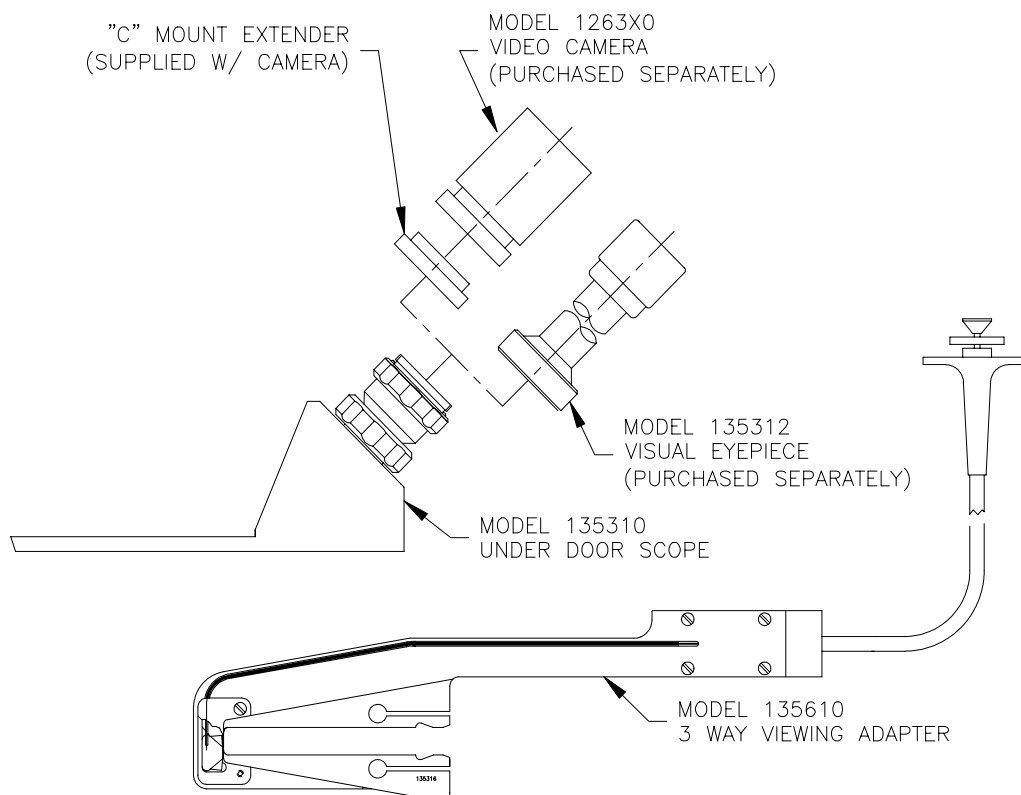

STANDARD VIDEO AND VISUAL SET-UP

NIGHT VISION SCOPE - VISUAL CONNECTION

1. Screw ITI Model 135312 Visual Eyepiece onto the scope's "C" mount.
2. Attach ITI Model 126070/41mm Visual Adapter to the back of the Eyepiece.
3. Remove lens from ITI Model 135630 NVPS. Screw NVPS onto the back of the Visual Adapter. Remove protective cap from NVPS and attach rubber eyeguard.
4. Focus scope by turning both the RVI's Focus Ring and the Night Vision Scope's eyepiece focus.

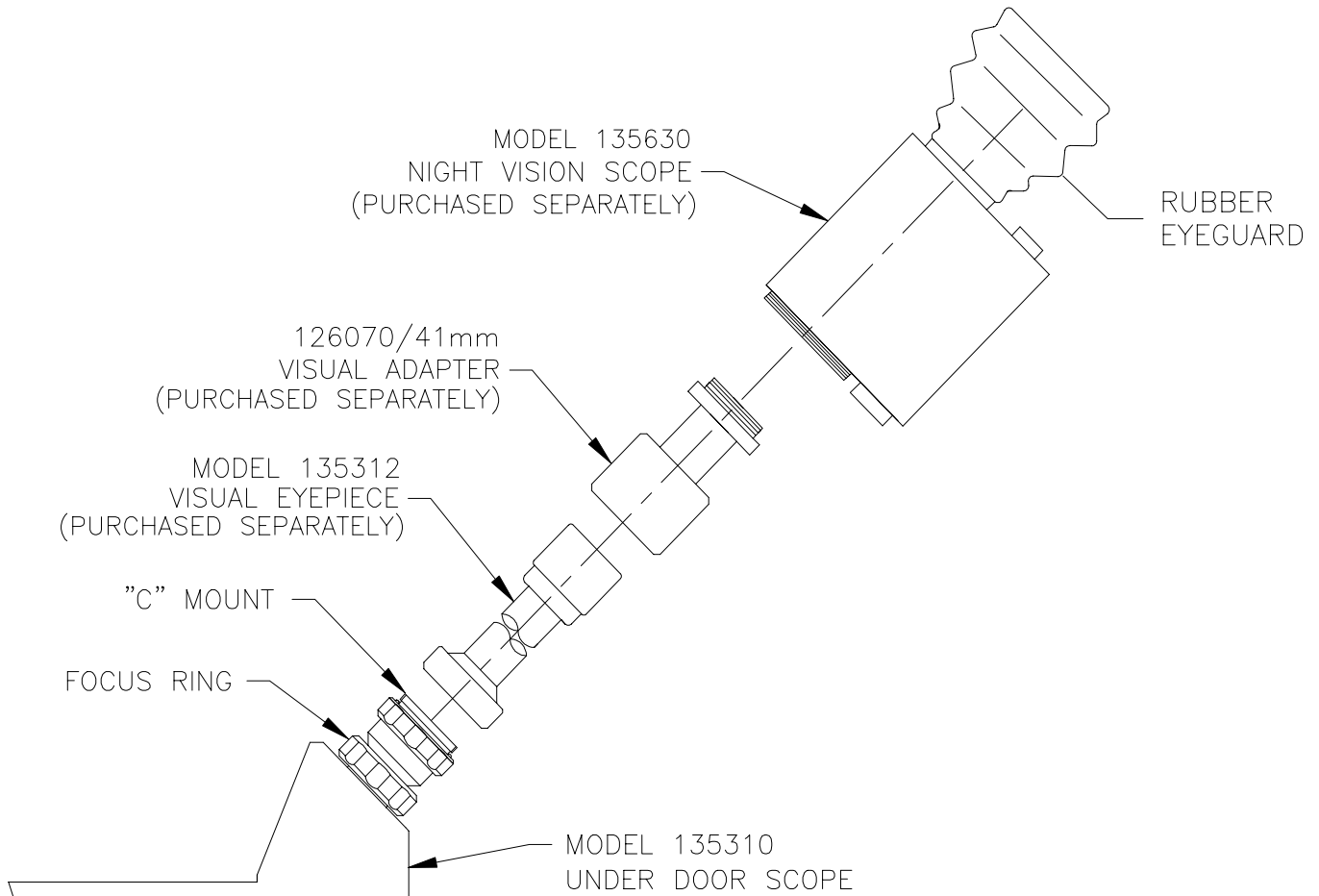

NIGHT VISION SCOPE - VIDEO CONNECTION

1. Screw 2X Adapter from NVPS Nav II & III Adapter Kit onto the RVI's "C" mount.
2. Unscrew the lens and the protective cap from ITI Model 135630 NVPS. Screw the NVPS onto the 2X Adapter.
3. From the NAV II & III Adapter Kit, screw on the NVPS relay lens to the ITI Model 135630 NVPS (lens will only adapt one way).
4. If using a 1/2" format CCD camera just simply screw on the camera. For use with 1/3" CCD cameras, use the "C" Mount Extender supplied with the camera or adapter kit. Screw "C" Mount Extender to camera until it bottoms out. Screw camera with extender to the NVPS relay lens.
5. Focus scope by turning both the RVI's Focus Ring and the Night Vision Scope's eyepiece focus until image is clear.

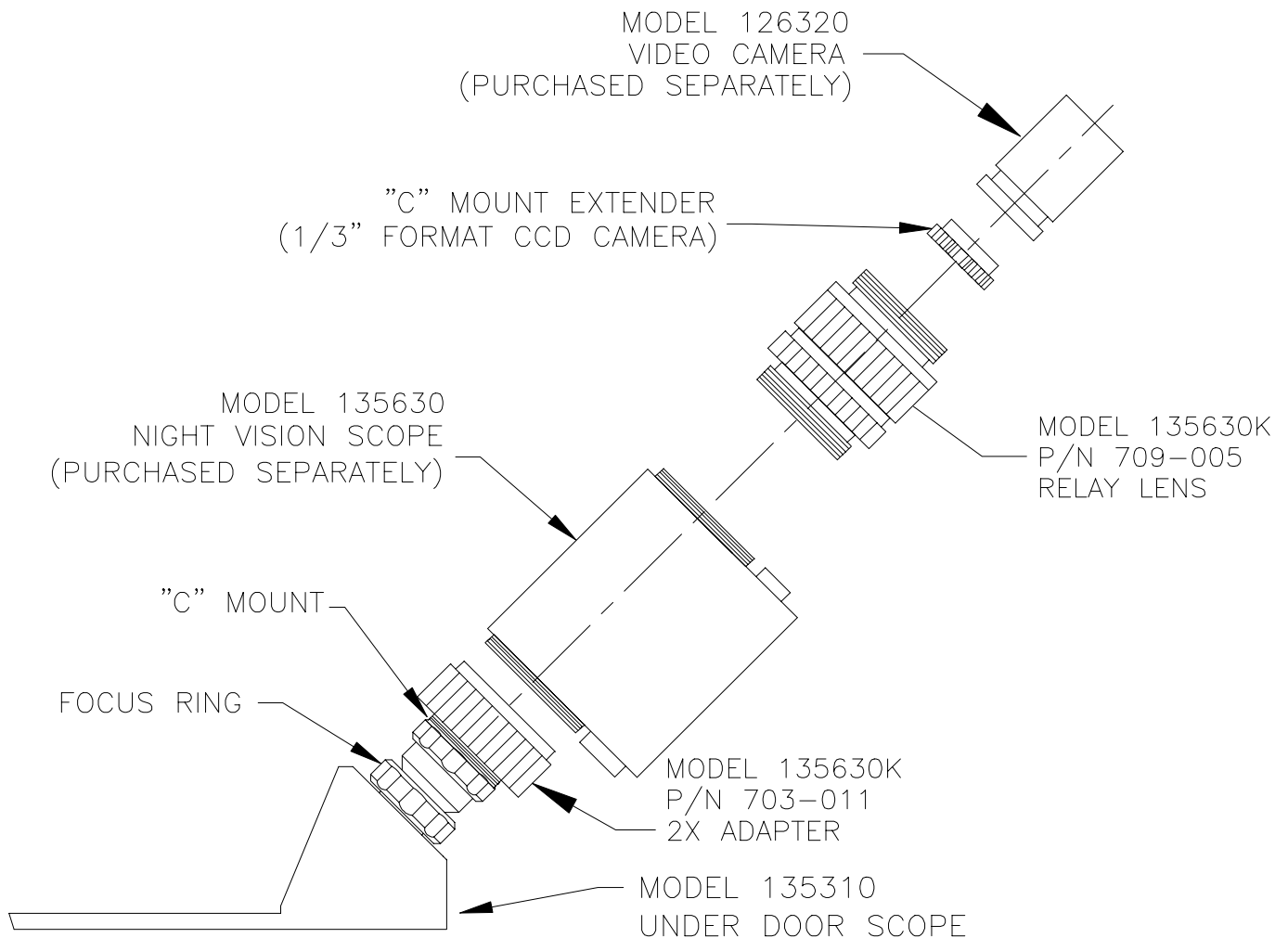

INFRARED EMITTER PLATE

12 Volt Battery Pack

1. Remove power cord from battery pack storage pouch.
2. Insert power cord plug into receptacle on Infrared Emitter Plate by rotating it until it locks into place.

Charging the 12 Volt Battery Pack

1. Disconnect power cord plug from Infrared Emitter Plate.
2. Insert power cord plug into Battery Charger receptacle.
3. Plug Battery Charger into a 110VAC/ 60Hz wall outlet. Allow 12-16 hours for battery to fully recharge.

AC Power Supply

1. Plug Power Supply into a 110VAC/ 60Hz wall outlet.
2. Insert power cord plug into receptacle on Infrared Emitter Plate by rotating it until it locks into place.

Operating Infrared Emitter Plate

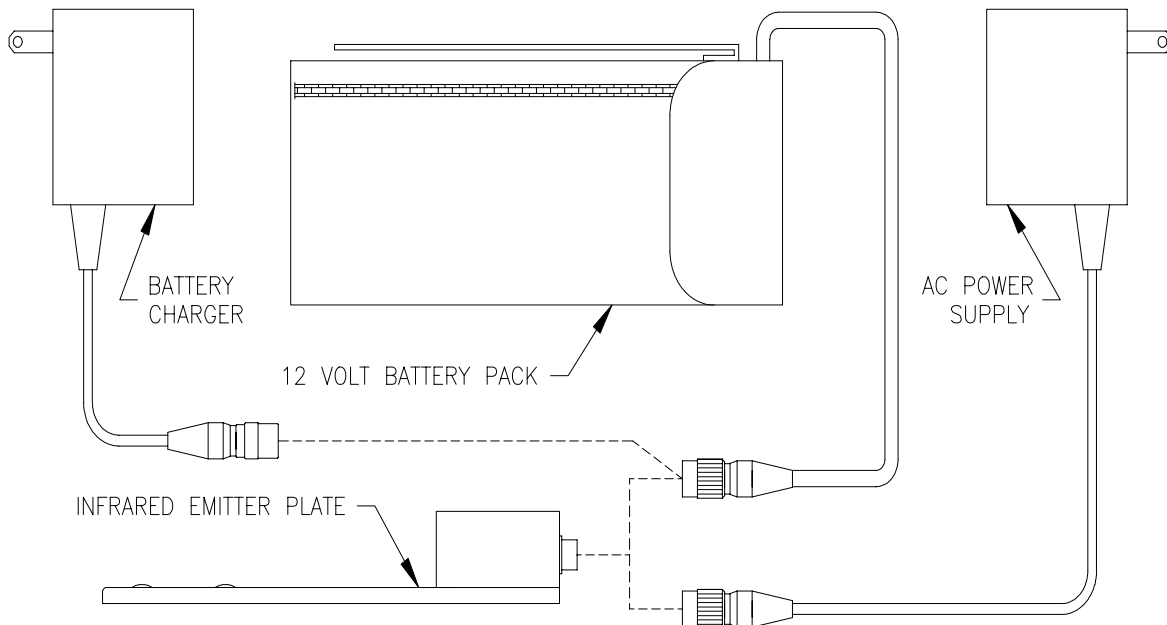

1. Hold Infrared Emitter Plate by black plastic housing, flat side down. Slide distal end of plate underneath door.
2. Slide or pivot Infrared Emitter Plate around to vary intensity of Infrared light emitted into room.
3. To disconnect either AC Power Supply or 12-Volt Rechargeable Battery Pack from Infrared Emitter Plate, pull back housing on power cord plug and remove from receptacle.



TELESCOPIC ARM

1. Securely screw threaded stud on Telescopic Arm into threaded hole provided on back of scope.
2. Turn Tension Adjust Ring to adjust amount of drag on rotary mount.
3. Fully extend Telescopic Arm until it locks into place.
4. Adjust Swivel Mount on Telescopic Arm by holding the scope firmly and pivoting the Arm.
5. Moving the handle on Telescopic Arm remotely adjusts location and viewing direction of scope.
6. To collapse Telescopic Arm, disengage lock by pulling back on handle logo ring. Guide arm into handle.

TROUBLESHOOTING GUIDE

Symptom	Possible Problem	Remedy
Dark Image 	Room is extremely dark	Use low light sensitivity CCD
	Dirt on external optical surfaces	Clean optics
	Dirt or liquid on internal optical surfaces	Return to ITI for repair
Image Not Clear 	Dirt on external optical surfaces	Clean optics
	Scope not focused	Focus scope
	Dirt or liquid on internal optical surfaces	Return to ITI for repair
	1/3" CCD without "C" Mount Extender	Use "C" Mount Extender
	1/2" CCD with "C" Mount Extender	Take off "C" Mount Extender
No Image 	Dirt on external optical surfaces	Clean optics
	Scope not inserted completely under door	Check scope insertion path
	Scope is damaged	Return to ITI for repair

INSTRUMENT CARE

CLEANING AFTER USE

Wipe instrument after use with a soft, clean cloth. If instrument is soiled, use a non-abrasive, neutral detergent on a damp cloth to clean it. Always store the instrument in a protective case.

NOTE: DO NOT IMMERGE INSTRUMENT IN LIQUID.

CLEANING OF OPTICS

Should cleaning of external surfaces be necessary, blow off dust with a triple-filtered, high pressure optical quality dusting spray. Wipe surface with a clean cotton swab moistened with laboratory grade alcohol. Excess alcohol can be blown away with the spray.

ITI Model 126110 RVI Cleaning Kit may be used.

CLEANING OF MIRROR

THE MIRROR SURFACE ON THE RIGHT ANGLE ADAPTER SHOULD **NEVER BE TOUCHED**. TOUCHING THE MIRROR WILL CAUSE SCRATCHES THAT WILL DETERIORATE THE IMAGE QUALITY.

Blow off dust with a triple-filtered, high pressure optical quality dusting spray. Flush with alcohol to remove debris.

ITI Model 126110 RVI Cleaning Kit may be used.

PRECAUTIONS

Do not use beyond recommended temperatures:

Maximum 150° F (65° C)
Minimum 32° F (0° C)

Do not allow instrument to contact live or exposed wiring. It is an excellent conductor.

REPAIR POLICY

If your equipment requires factory attention, contact ITI's Customer Service Dept. at (413) 562-3606 for a Return Authorization Number. Please be prepared to furnish your model and serial numbers. Return the equipment to ITI, freight prepaid. Ship to:

Instrument Technology, Inc.
33 Airport Road
Westfield, MA 01085-1357

Please note Return Authorization Number on Purchase Orders, and all shipping documents.

Upon receipt of your equipment, ITI will assess its condition to determine if repairs are needed. If repairs are required, we will quote repair costs and a schedule for repairs. Your options at this point are:

1) **Accept Repair**

To proceed with the repair, ITI will require a purchase order for the full quoted repair price.

2) **Decline Repair - Upgrade to a New Instrument**

Choosing this option requires a purchase order for the new equipment at its quoted price. ITI will ship out the next available unit.

3) **Decline Repair**

Please Note - Most repair evaluations require a partial or complete disassembly of the equipment. **Once disassembled, it is impossible to return it to the customer in "as received" condition.** At the customer's option, ITI will either return your equipment in its disassembled state, or dispose of it.